

INTERNATIONAL
STANDARD

ISO
4032

Third edition
1999-08-15

**Hexagon nuts, style 1 — Product
grades A and B**

Écrous hexagonaux, style 1 — Grades A et B



Reference number
ISO 4032:1999(E)

Foreword

ISO (the International Organization for Standardization) is a worldwide federation of national standards bodies (ISO member bodies). The work of preparing International Standards is normally carried out through ISO technical committees. Each member body interested in a subject for which a technical committee has been established has the right to be represented on that committee. International organizations, governmental and non-governmental, in liaison with ISO, also take part in the work. ISO collaborates closely with the International Electrotechnical Commission (IEC) on all matters of electrotechnical standardization.

International Standards are drafted in accordance with the rules given in the ISO/IEC Directives, Part 3.

Draft International Standards adopted by the technical committees are circulated to the member bodies for voting. Publication as an International Standard requires approval by at least 75 % of the member bodies casting a vote.

International Standard ISO 4032 was prepared by Technical Committee ISO/TC 2, *Fasteners*.

This third edition cancels and replaces the second edition (ISO 4032:1986) which has been technically revised.

© ISO 1999

All rights reserved. Unless otherwise specified, no part of this publication may be reproduced or utilized in any form or by any means, electronic or mechanical, including photocopying and microfilm, without permission in writing from the publisher.

International Organization for Standardization
Case postale 56 • CH-1211 Genève 20 • Switzerland
Internet iso@iso.ch

Printed in Switzerland

Introduction

This International Standard is part of the complete ISO product standard series on external hexagon drive fasteners. The series comprises:

- a) hexagon head bolts (ISO 4014 to ISO 4016 and ISO 8765);
- b) hexagon head screws (ISO 4017, ISO 4018 and ISO 8676);
- c) hexagon nuts (ISO 4032 to ISO 4036, ISO 8673 to ISO 8675);
- d) hexagon bolts with flange (ISO 4162 and ISO 15071);
- e) hexagon nuts with flange (ISO 4161 and ISO 10663);
- f) structural bolts and nuts (ISO 4775, ISO 7411 to ISO 7414 and ISO 7417).

Hexagon nuts, style 1 — Product grades A and B

1 Scope

This International Standard specifies the characteristics of hexagon nuts, style 1, with threads from M1.6 up to including M64, with product grade A for threads $d \leq M16$ and product grade B for threads $d > M16$.

If, in special cases, specifications other than those listed in this International Standard are required, they should be selected from existing International Standards, for example ISO 724, ISO 898-2, ISO 965-1, ISO 3506-2 and ISO 4759-1.

NOTE For hexagon nuts style 2, see ISO 4033.

2 Normative references

The following normative documents contain provisions which, through reference in this text, constitute provisions of this International Standard. For dated references, subsequent amendments to, or revisions of, any of these publications do not apply. However, parties to agreements based on this International Standard are encouraged to investigate the possibility of applying the most recent editions of the normative documents indicated below. For undated references, the latest edition of the normative document referred to applies. Members of ISO and IEC maintain registers of currently valid International Standards.

ISO 225:1983, *Fasteners — Bolts, screws, studs and nuts — Symbols and designations of dimensions.*

ISO 724:1993, *ISO general-purpose metric screw threads — Basic dimensions.*

ISO 898-2:1992, *Mechanical properties of fasteners — Part 2: Nuts with specified proof load values — Coarse thread.*

ISO 965-1:1998, *ISO general purpose metric screw threads — Tolerances — Part 1: Principles and basic data.*

ISO 3269:—¹⁾, *Fasteners — Acceptance inspection.*

ISO 3506-2:1997, *Mechanical properties of corrosion-resistant stainless steel fasteners — Part 2: Nuts.*

ISO 4042:1999, *Fasteners — Electroplated coatings.*

ISO 4759-1:—²⁾, *Tolerances for fasteners — Part 1: Bolts, screws, studs and nuts — Product grades A, B and C.*

ISO 6157-2:1988, *Fasteners — Surface discontinuities — Part 2: Nuts.*

ISO 8839:1986, *Mechanical properties of fasteners — Bolts, screws, studs and nuts made of non-ferrous metals.*

ISO 8992:1986, *Fasteners — General requirements for bolts, screws, studs and nuts.*

ISO 10683:—³⁾, *Fasteners — Non-electrolytically applied zinc flake coatings.*

¹⁾ To be published. (Revision of ISO 3269:1988)

²⁾ To be published. (Revision of ISO 4759-1:1978)

³⁾ To be published.

3 Dimensions

See Figure 1 and Tables 1 and 2.

Symbols and descriptions of dimensions are defined in ISO 225.

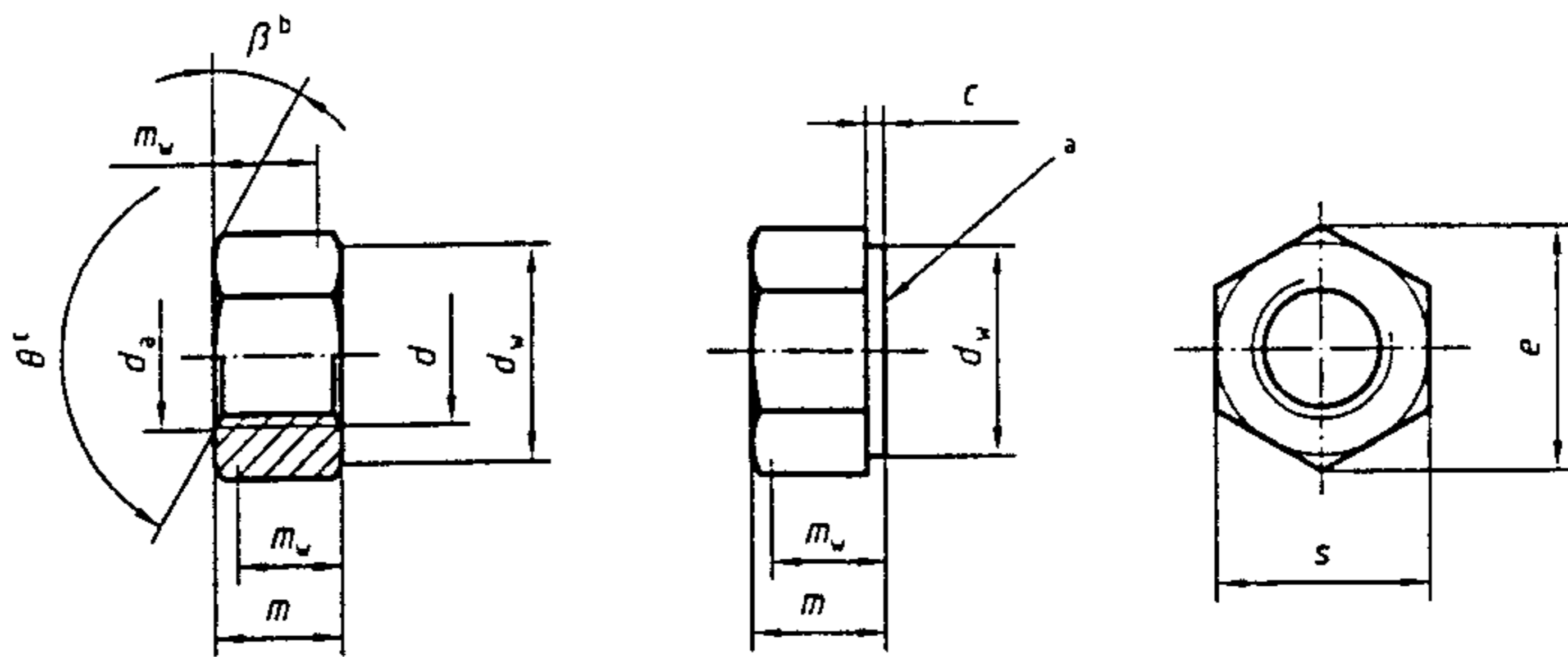

- a Washer-face form to be ordered separately
- b $\beta = 15^\circ$ to 30°
- c $\theta = 90^\circ$ to 120°

Figure 1

Table 1 — Preferred threads

Dimensions in millimetres

Thread (<i>d</i>)		M1.6	M2	M2.5	M3	M4	M5	M6	M8	M10	M12
p_a		0.35	0.4	0.45	0.5	0.7	0.8	1	1.25	1.5	1.75
<i>c</i>	max.	0.2	0.2	0.3	0.40	0.40	0.50	0.50	0.60	0.60	0.60
	min.	0.1	0.1	0.1	0.15	0.15	0.15	0.15	0.15	0.15	0.15
d_a	max.	1.84	2.3	2.9	3.45	4.6	5.75	6.75	8.75	10.8	13
	min.	1.60	2.0	2.5	3.00	4.0	5.00	6.00	8.00	10.0	12
d_w	min.	2.4	3.1	4.1	4.6	5.9	6.9	8.9	11.6	14.6	16.6
<i>e</i>	min.	3.41	4.32	5.45	6.01	7.66	8.79	11.05	14.38	17.77	20.03
<i>m</i>	max.	1.30	1.60	2.00	2.40	3.2	4.7	5.2	6.80	8.40	10.80
	min.	1.05	1.35	1.75	2.15	2.9	4.4	4.9	6.44	8.04	10.37
m_w	min.	0.8	1.1	1.4	1.7	2.3	3.5	3.9	5.2	6.4	8.3
<i>s</i>	nom. = max.	3.20	4.00	5.00	5.50	7.00	8.00	10.00	13.00	16.00	18.00
	min.	3.02	3.82	4.82	5.32	6.78	7.78	9.78	12.73	15.73	17.73

Thread (<i>d</i>)		M16	M20	M24	M30	M36	M42	M48	M56	M64
p_a		2	2.5	3	3.5	4	4.5	5	5.5	6
<i>c</i>	max.	0.8	0.8	0.8	0.8	0.8	1.0	1.0	1.0	1.0
	min.	0.2	0.2	0.2	0.2	0.2	0.3	0.3	0.3	0.3
d_a	max.	17.3	21.6	25.9	32.4	38.9	45.4	51.8	60.5	69.1
	min.	16.0	20.0	24.0	30.0	36.0	42.0	48.0	56.0	64.0
d_w	min.	22.5	27.7	33.3	42.8	51.1	60	69.5	78.7	88.2
<i>e</i>	min.	26.75	32.95	39.55	50.85	60.79	71.3	82.6	93.56	104.86
<i>m</i>	max.	14.8	18.0	21.5	25.6	31.0	34.0	38.0	45.0	51.0
	min.	14.1	16.9	20.2	24.3	29.4	32.4	36.4	43.4	49.1
m_w	min.	11.3	13.5	16.2	19.4	23.5	25.9	29.1	34.7	39.3
<i>s</i>	nom. = max.	24.00	30.00	36	46	55.0	65.0	75.0	85.0	95.0
	min.	23.67	29.16	35	45	53.8	63.1	73.1	82.8	92.8

a *p* is the pitch of the thread.

Table 2 — Non-preferred threads

Dimensions in millimetres

Thread (<i>d</i>)		M3.5	M14	M18	M22	M27	M33	M39	M45	M52	M60
p_a		0.6	2	2.5	2.5	3	3.5	4	4.5	5	5.5
<i>c</i>	max.	0.40	0.60	0.8	0.8	0.8	0.8	1.0	1.0	1.0	1.0
	min.	0.15	0.15	0.2	0.2	0.2	0.2	0.3	0.3	0.3	0.3
d_a	max.	4.0	15.1	19.5	23.7	29.1	35.6	42.1	48.6	56.2	64.8
	min.	3.5	14.0	18.0	22.0	27.0	33.0	39.0	45.0	52.0	60.0
d_w	min.	5	19.6	24.9	31.4	38	46.6	55.9	64.7	74.2	83.4
<i>e</i>	min.	6.58	23.36	29.56	37.29	45.2	55.37	66.44	76.95	88.25	99.21
<i>m</i>	max.	2.80	12.8	15.8	19.4	23.8	28.7	33.4	36.0	42.0	48.0
	min.	2.55	12.1	15.1	18.1	22.5	27.4	31.8	34.4	40.4	46.4
d_w	min.	2	9.7	12.1	14.5	18	21.9	25.4	27.5	32.3	37.1
<i>s</i>	nom. = max.	6.00	21.00	27.00	34	41	50	60.0	70.0	80.0	90.0
	min.	5.82	20.67	26.16	33	40	49	58.8	68.1	78.1	87.8

a *p* is the pitch of the thread.

4 Specifications and reference standards

See Table 3.

Table 3 — Specifications and reference standards

Material		Steel	Stainless steel	Non-ferrous metal
General requirements	International Standard	ISO 8992		
	Tolerance	6H		
Thread	International Standards	ISO 724, ISO 965-1		
	Property class ^a	$d < M3$: as agreed $M3 \leq d \leq M39$: 6, 8, 10 $d > M39$: as agreed	$d \leq M24$: A2-70, A4-70 $M24 < d \leq M39$: A2-50, A4-50 $d > M39$: as agreed	Materials specified in ISO 8839
International Standards	$M3 \leq d \leq M39$: ISO 898-2 $d < M3$ and $d > M39$: as agreed	$d \leq M39$: ISO 3506-2 $d > M39$: as agreed		
Tolerances	Product grade	$d < M16$: A $d > M16$: B		
	International Standard	ISO 4759-1		
Finish and/or coating	As processed	Requirements for electroplating are covered in ISO 4042 Requirements for non-electrolytically applied zinc flake coatings are covered in ISO 10683 If different electroplating requirements are desired or if requirements are needed for other finishes, they should be agreed between customer and supplier. Limits for surface discontinuities are covered in ISO 6157-2	Plain	Plain Requirements for electroplating are covered in ISO 4042
	Acceptability	For acceptance procedure, see ISO 3269.		
^a For other property classes see ISO 898-2 for steel and ISO 3506-2 for stainless steel respectively.				

5 Designation

EXAMPLE

A hexagon nut, style 1, with thread M12 and property class 8 is designated as follows:

Hexagon nut ISO 4032 - M12 - 8

Bibliography

- [1] ISO 4014:1999, *Hexagon head bolts — Product grades A and B.*
- [2] ISO 4015:1979, *Hexagon head bolts — Product grade B — Reduced shank (shank diameter approximately equal to pitch diameter).*
- [3] ISO 4016:1999, *Hexagon head bolts — Product grade C.*
- [4] ISO 4017:1999, *Hexagon head screws — Product grades A and B.*
- [5] ISO 4018:1999, *Hexagon head screws — Product grade C.*
- [6] ISO 4033:1999, *Hexagon nuts, style 2 — Product grades A and B.*
- [7] ISO 4034:1999, *Hexagon nuts — Product grade C.*
- [8] ISO 4035:1999, *Hexagon thin nuts (chamfered) — Product grades A and B.*
- [9] ISO 4036:1999, *Hexagon thin nuts (unchamfered) — Product grade B.*
- [10] ISO 4161:1999, *Hexagon nuts with flange — Coarse thread.*
- [11] ISO 4162:—⁴⁾, *Hexagon bolts with flange — Small series — Product grade combination A/B.*
- [12] ISO 4775:1984, *Hexagon nuts for high-strength structural bolting with large width across flats — Product grade B — Property classes 8 and 10.*
- [13] ISO 7411:1984, *Hexagon bolts for high-strength structural bolting with large width across flats (thread lengths according to ISO 888) — Product grade C — Property classes 8.8 and 10.9.*
- [14] ISO 7412:1984, *Hexagon bolts for high-strength structural bolting with large width across flats (short thread length) — Product grade C — Property classes 8.8 and 10.9.*
- [15] ISO 7413:1984, *Hexagon nuts for structural bolting, style 1, hot-dip galvanized (oversize tapped) — Product grades A and B — Property classes 5, 6 and 8.*
- [16] ISO 7414:1984, *Hexagon nuts for structural bolting with large width across flats, style 1 — Product grade B — Property class 10.*
- [17] ISO 7417:1984, *Hexagon nuts for structural bolting, style 2, hot-dip galvanized (oversize tapped) — Product grade A — Property class 9.*
- [18] ISO 8673:1999, *Hexagon nuts, style 1, with metric fine pitch thread — Product grades A and B.*
- [19] ISO 8674:1999, *Hexagon nuts, style 2, with metric fine pitch thread — Product grades A and B.*
- [20] ISO 8675:1999, *Hexagon thin nuts (chamfered) with metric fine pitch thread — Product grades A and B.*
- [21] ISO 8676:1999, *Hexagon head screws with metric fine pitch thread — Product grades A and B.*

⁴⁾ To be published. (Revision of ISO 4162:1990)

[22] ISO 8765:1999, *Hexagon head bolts with metric fine pitch thread — Product grades A and B.*

[23] ISO 10663:1999, *Hexagon nuts with flange — Fine pitch thread.*

[24] ISO 15071:1999, *Hexagon bolts with flange — Small series — Product grade A.*

